

TRT800RT - OLED Remote Control Unit



P/N 800ATC-H-(Rxx)-(Rxx)

Operation and Installation

(Document-No. 03.202.010.71e)

Change History

Revision	Date	Description of Change
1.00	22.10.2012	First Release

List of Service-Bulletins (SB)

Service Bulletins have to be inserted into this manual and to be enlisted in the following table.

SB No	Rev. No.	Issue Date	Insertion Date	Name

Survey of Variants

Part Number	Description
P/N 800ATC-H-(R00)-(R00)	First version with OLED-Display



Table of Contents

1	GENERAL	4
1.1	Symbols	4
1.2	Abbreviations	5
1.3	Customer Support	6
1.4	Features	6
2	OPERATION	7
2.1	Controls	7
2.2	Switch ON/OFF	9
2.3	Display - Indications	10
2.4	Display-Brightness	11
2.5	Flight-ID (FID)	11
2.5.1	Display Flight-ID	12
2.5.2	Configure Flight-ID	12
2.6	Transponder Mode selection.....	13
2.7	Squawk-Setting	13
2.8	VFR – Squawk	14
2.9	ID – Special Position Identification (SPI): “Squawk Ident”	14
3	INSTALLATION	15
3.1	Notes	15
3.2	Scope of Delivery	15
3.3	Unpacking and Inspecting of the Equipment	15
3.4	Mounting	16
3.5	Equipment Connections	17
3.5.1	Electrical Connections	17
3.6	Wiring	17
3.6.1	Conductor Cross Section.....	17
3.6.2	Pin Assignment.....	17
3.7	Post-Installation Check	18
3.8	Drawings	19
3.8.1	Dimensions	19
3.8.2	Mounting Advices	19
4	APPENDIX	20
4.1	Technical Data	20
4.2	Environmental Conditions	21

1 GENERAL

This manual contains information about the physical, mechanical and electrical characteristics and about installation and operation of the transponder remote control TRT800RT.

1.1 Symbols

	Advices whose non-observance can cause radiation damage to the human body or ignition of combustible materials
	Advices whose non-observance can cause damage to the device or other parts of the equipment.
	Supplementary information

1.2 Abbreviations

Abb.	Meaning	Explanation
FID	Flight ID	Flight plan number or if not assigned registration number of aircraft
SPI	Special Position Identification	Activation on request by controllers „Squawk Ident“, transmits SPI Pulse for 18 seconds, which highlights the respective traffic item on the controllers radar screen

1.3 Customer Support

In order to facilitate a rapid handling of return shipments, please follow the instructions of the input guide „Reshipment RMA“ provided at the **Service-Area** within the Funkwerk Avionics web portal www.funkwerk-avionics.com.



Any suggestions for improvement of our manuals are welcome. Contact: service@funkwerk-avionics.com.



Informations on software updates are available at Funkwerk Avionics

1.4 Features

Remote control and indication of all transponder settings/data during standard operation (e.g. squawk code, operation mode, altitude etc).

Ideal for tandem seated aircraft:

Use of transponder still possible without activation of remote control

Automatic deactivation of remote control on deactivation of transponder





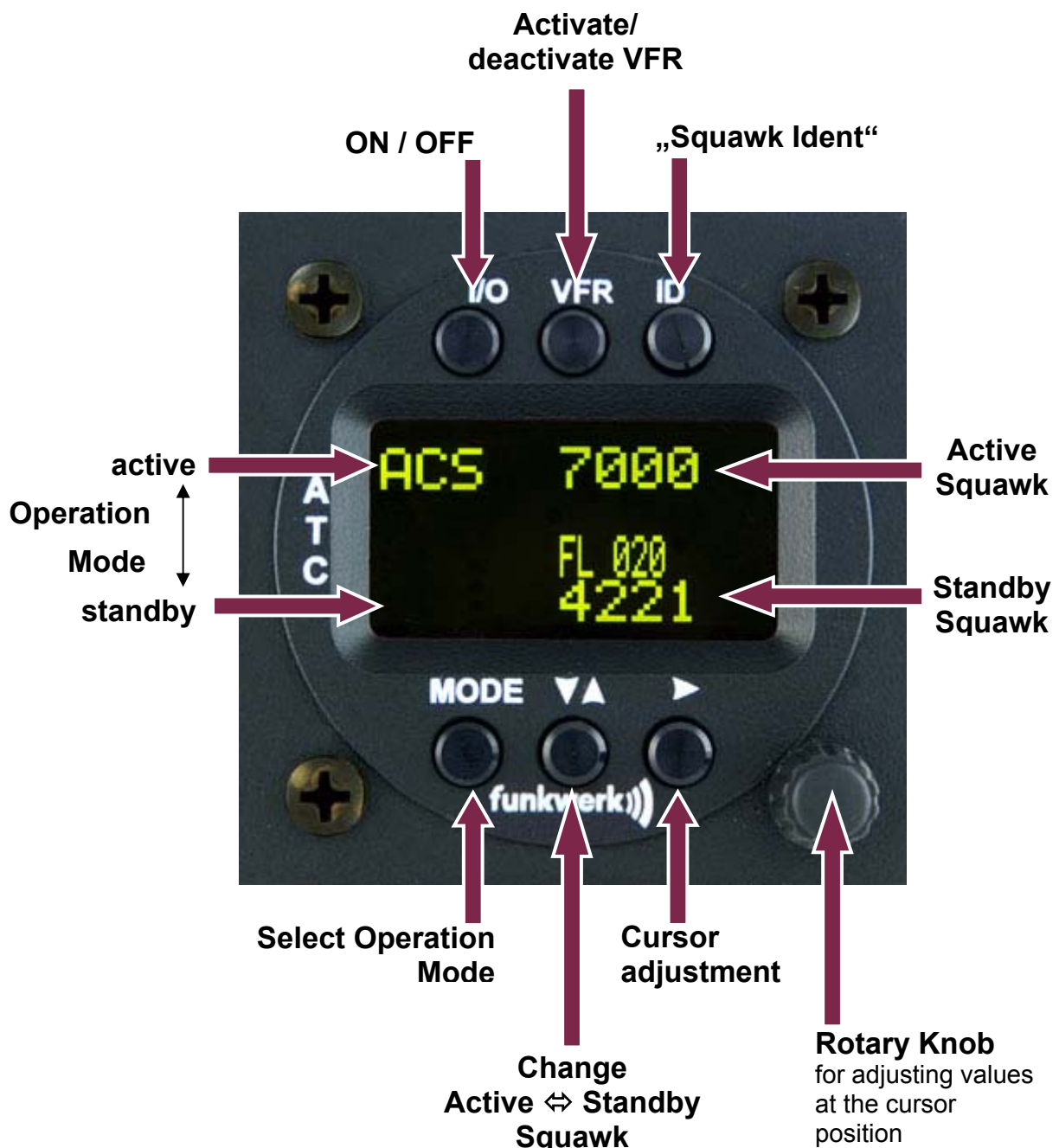

2 OPERATION

2.1 Controls



If remote unit settings are inconsistent with transponder settings as a result of short time transmission problem (e.g. simultaneous user inputs) remote unit settings will be reverted to current transponder setting.



	ON/OFF	<ul style="list-style-type: none"> ▶ Switch ON press button for approx. 0,5 s ▶ Switch OFF press button for approx. 3 s
	VFR	<ul style="list-style-type: none"> ▶ activate/deactivate VFR Squawk (press shortly) ▶ store active Squawk as VFR/VFRW-Squawk (press button 3 s, →2.8)
	CHANGE	<ul style="list-style-type: none"> ▶ change between active and standby-Squawk ▶ works as cursor back button (opposite function of the cursor button) during entering values and also for navigating backwards through the configuration menu (→Fehler! Verweisquelle konnte nicht gefunden werden.)
	IDENT	<ul style="list-style-type: none"> ▶ „Squawk Ident“, sends Ident marking (SPI) for 18 s (→ 2.9) ▶ Enter Flight-ID (FID) setup (in standby mode, press button for approx. 5s)
	MODE	<ul style="list-style-type: none"> ▶ Select transponder operational mode (→ 2.6)
	CURSOR	<ul style="list-style-type: none"> ▶ Set position of Cursor
	Rotary Knob	<ul style="list-style-type: none"> ▶ Adjust/Enter values at current cursor position, select options; set standby Squawk (→ 2.7)

2.2 Switch ON/OFF

Switch **ON**: press ● I/O for 0.5 s

Switch **OFF**: press ● I/O for 3 s

2.2.1 Display information after power up

After turning-on the display appears as follows (example):

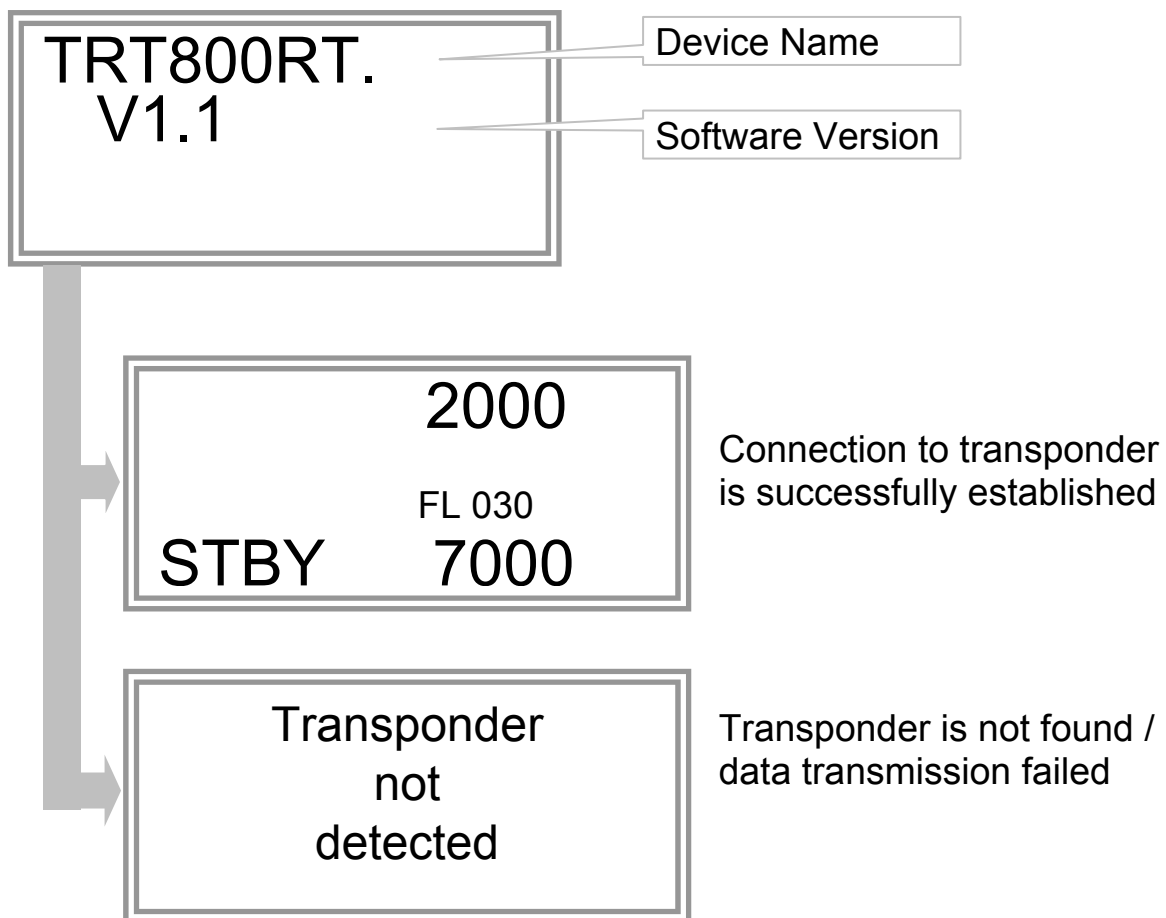

2.3 Display - Indications

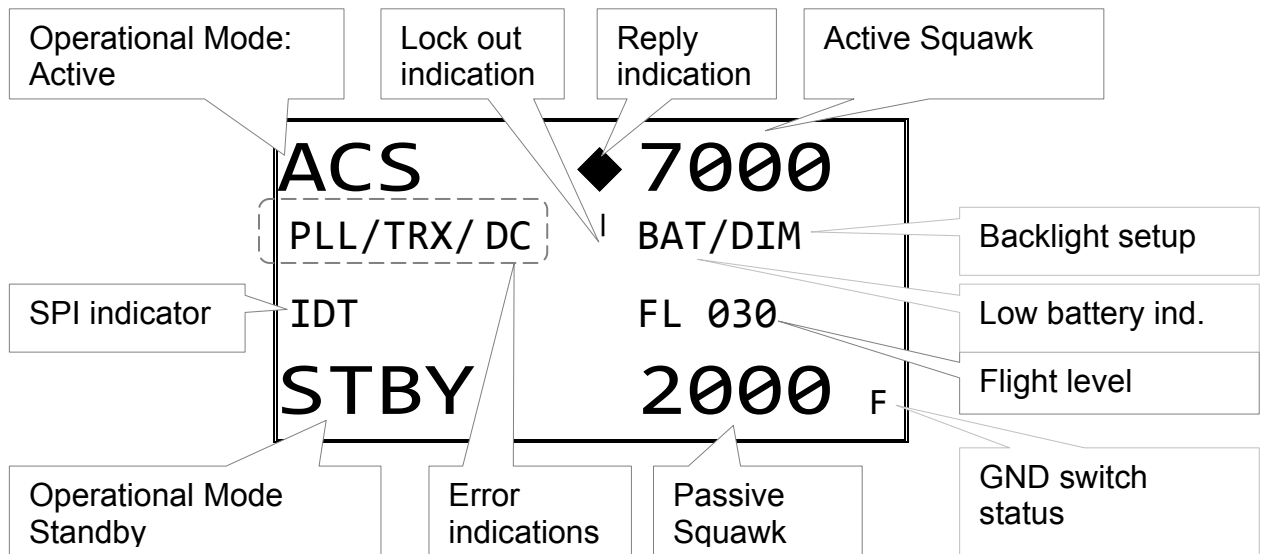

Value	Meaning	Remarks
7000	active Squawk	
2000	Standby Squawk	Could be changed with active Squawk by pressing ● ▲ ▼
FL 010	Flight Level	Flight Level (in 100 ft steps)
FLerr	Invalid altitude measuring	
ACS	Operational Mode (STBY, A-S, ACS, AC, A)	Modes see section 2.6
IDT	transmits Ident-Marking (SPI)	ID („Squawk Ident“) has been pressed – active for 18 s
◆	Transponder replies on Mode-S, Mode-A or Mode-C interrogations	No indication on ADSB and squitter transmission
	Transponder is locked by a ground station and will be directly addressed	Lock Information (indicated below the diamond)
F	in-flight	Ground-Switch-Info (if available)
G	on-ground	

Error indicators		
PLL	PLL Error	Internal Error
TRX	Transmit Failure	Check antenna and wiring
DC	Low internal voltage	Internal error
FPG	FPGA-Failure	Internal error
BAT	Battery Power too low	maybe battery/generator fault

Note: Short time indication symbols (e.g. lock-out indication or reply indication) are displayed/cleared in different time interval or delayed in comparison with TRT800H screen.

2.4 Display-Brightness

In active mode (not standby) press   for 2 s

Display indicates “DIM” → Adjust brightness (DIM) with rotary knob

Return to normal operation: press   or wait 5 s.

2.5 Flight-ID (FID)

The FID is an identifier required by Mode-S Operation. During future application of flight plans a FID could be assigned on a per flight basis. If no FID is assigned (today's normal case) the registration marking of the aircraft should be used as FID. The FID should not contain dashes or blanks.

2.5.1 Display Flight-ID

Press **MODE** (repeatedly) until „STBY“ appears

Press and hold **ID** while a counter is shown beside the active squawk.
During a few seconds Flight Identification is displayed



2.5.2 Configure Flight-ID

Press **MODE** (repeatedly) until „STBY“ appears

Press and hold **ID** while a counter is shown beside the active squawk.
Release **ID** when “CHANGE FID” is displayed

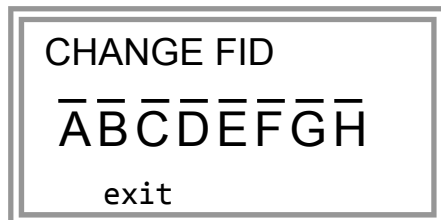

Enter Flight-Id with cursor button **▶** and rotary knob

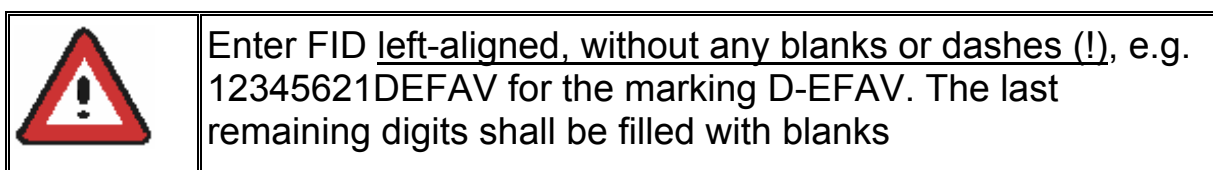

Press **MODE** to save and return to STBY

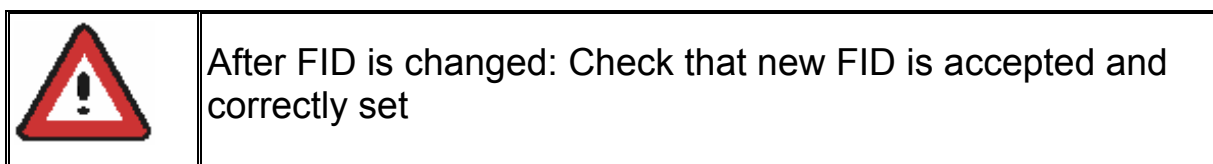

2.6 Transponder Mode selection

Press **MODE** (repeatedly) to select from following Modes:

- **STBY** → „Standby“
Transponder does not respond to any interrogation. Squitter and ADS-B output is not active.
- **ACS** → „Mode A+C+S“
Standard condition; transponder responds to mode A, C and S interrogations.
- **A-S** → „Mode A+S, no C“
Altitude is not transmitted (neither on C nor on S requests). All other Mode-S data as well as Mode-A replies are transmitted.

If no 24-bit address (AA) was defined or entered as “000000” the transponder works as Mode A-C transponder, in that case the following Modes are possible apart from Standby:

- **AC-** → „Mode A+C“
Transponder replies only on Mode A and Mode-C interrogations.
- **A--** → „Mode A“
Transponder replies only on Mode A interrogations.



In STBY (Standby) mode, all transponder transmissions are disabled completely! Therefore, the transponder is not visible in this mode to air traffic control or the anti-collision systems onboard other aircrafts.

Never use the STBY mode in flight unless you are requested to do so by air traffic control. Always remember to put the transponder in active mode prior to take off!

2.7 Squawk-Setting

The active Squawk is displayed in the upper line, while the standby Squawk is presented at the lower line.

Setting the Standby Squawk:

- Press **MODE** **▶** to set the cursor („^“), turn rotary knob to set numbers of the standby Squawk.
- Press **MODE** **▼▲** to activate the Standby Squawk (this moves the current active Squawk into Standby)

2.8 VFR – Squawk

The transponder features a user-defined squawk code for VFR-flight (factory setting: 7000):

- Activate VFR-Squawk:

Press **VFR** („VFR“ is indicated), now the active Squawk is moved into Standby but not visible because the indication of the Standby Squawk is overlapped by „VFR“

- Display Standby Squawk:

Press **VFR** or **▼▲** or use the **rotary knob** (the VFR-Squawk remains active!)

Example:

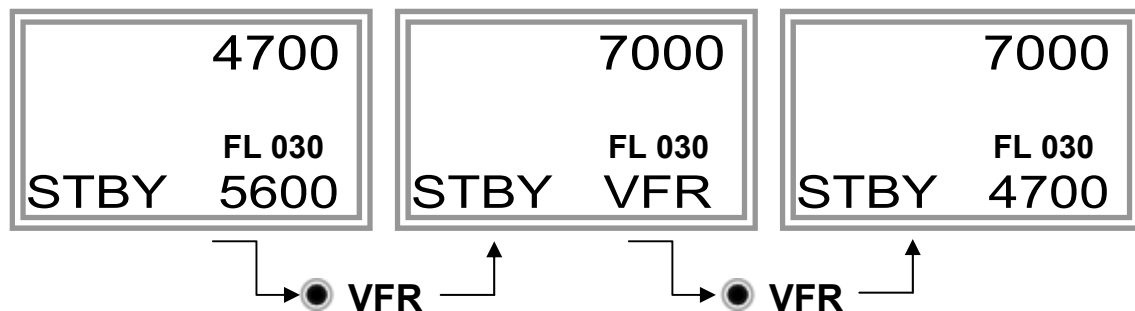

- Now the Standby Squawk can be adjusted by using the **rotary knob** and activated with **▼▲**.
- In order to store the current active Squawk as new VFR-Squawk (replacing the factory setting 7000):
Press and hold **VFR** until an „S“ is indicated (approx. 3 s); after releasing the button „VFR“ is shown

2.9 ID – Special Position Identification (SPI): “Squawk Ident”

Press ID to activate transmission of the special position identification pulse with every reply within 18 seconds; “IDT” appears on the display

By pressing **ID** a special position identification pulse (SPI) is transmitted with every reply within 18 seconds, which causes an accented marking on the Controller’s screen. The „Special Position Identification“ has to be activated after the „Squawk Ident“ request of the Controller.

3 INSTALLATION

3.1 Notes

The following suggestions should be considered before installing.

The assigned installation company will supply wiring. For diagrams refer to 3.6 Wiring.

Remote Header and cables shall be installed according to „FAA AC-143.13-2A Acceptable Methods, Techniques and Practices – Aircraft Alterations“ and the appropriate manufacturer’s instructions.

3.2 Scope of Delivery

Item name / number	Description
TRT800RT	Remote Header TRT800H-Remote Control Unit
ATR600RTK3	Connector
M4X8ZSW (3 pieces)	screw for panels up to 5 mm thickness
03.202.010.71e	Manual „Operation and Installation“
	EASA Form 1

3.3 Unpacking and Inspecting of the Equipment

Carefully unpack the equipment and inspect for transport damages. If a damage claim has to be filed, save the shipping container and all packing materials as evidence to your claim.



For storage or reshipment the original packaging should be used.

3.4 Mounting

- In cooperation with a maintenance shop, location and kind of the installation are specified. The maintenance shop can supply all cables. Suitable sets of cables are available from Funkwerk Avionics GmbH.
- Select a position away from heat sources. Care for adequate convection cooling.
- Leave sufficient space for the installation of cables and connectors.
- Avoid sharp bends and wiring close to control cables.
- Leave sufficient lead length for inspection or repair of the wiring of the connector (containing the memory), so that when the mounting hardware for the rear connectors is removed, the assembly may be pulled forward several inches.
- Bend the harness at the rear connectors to inhibit water droplets (formed due to condensation) from collecting in the connector.
- For mounting details/drawing refer to chapter 3.8.2 Mounting Advices.

3.5 Equipment Connections

3.5.1 Electrical Connections

One 9 pin D-SUB miniature connector includes all electrical connections.

	<p>When powering the remote control not by the output of the switched power output of the remote controlled device but directly by the aircraft's power supply, the power input line (+UB) must be equipped with an external fuse (1Amp./slow).</p>
---	---

3.6 Wiring

3.6.1 Conductor Cross Section

Power Supply (Power, GND): AWG20 (0,62 mm²)

Signals: AWG22 (0,38 mm²)

The conductors must be approved for aircraft use. RX and TX should be shielded individually, or at least be pair-twisted and shielded together.

3.6.2 Pin Assignment

Pin	Signal	Remarks
1	GND (Data)	-
2	Data TX	Output
3	-	
4	Light	Input
5	UB+	Power input
6	GND (Data)	
7	Data RX	Input
8	-	-
9	UB+	Power input ⁽¹⁾

	<p>⁽¹⁾UB+: Can be connected to switched power output of transponder.</p>
---	---

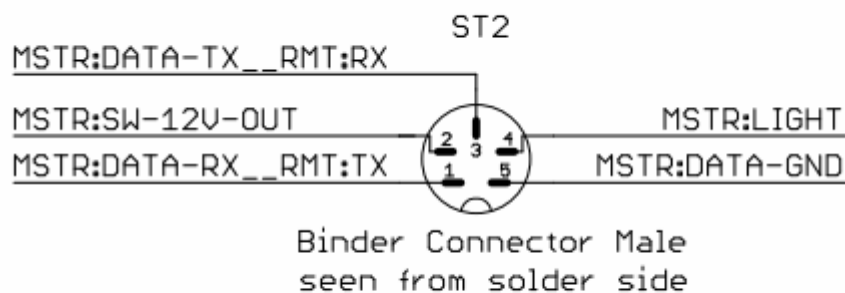
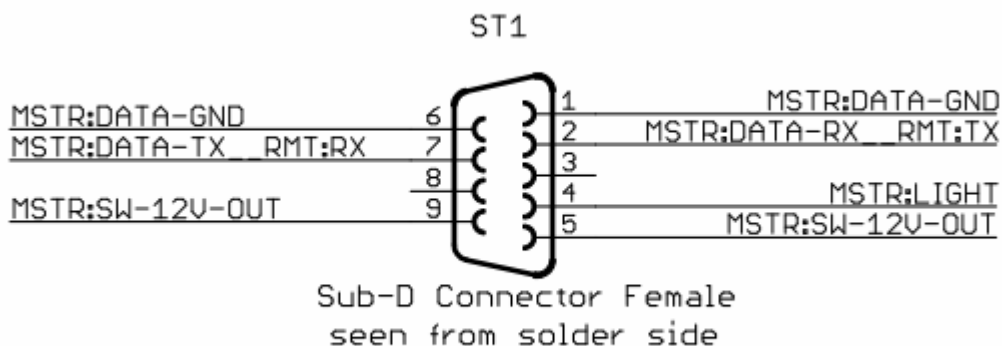

3.7 Post-Installation Check

	A certified maintenance shop must verify proper operation of remote control header".
---	--

All steering and control functions of the aircraft are to be examined, in order to exclude disturbances by the wiring.

3.8 Drawings

3.8.1 Dimensions

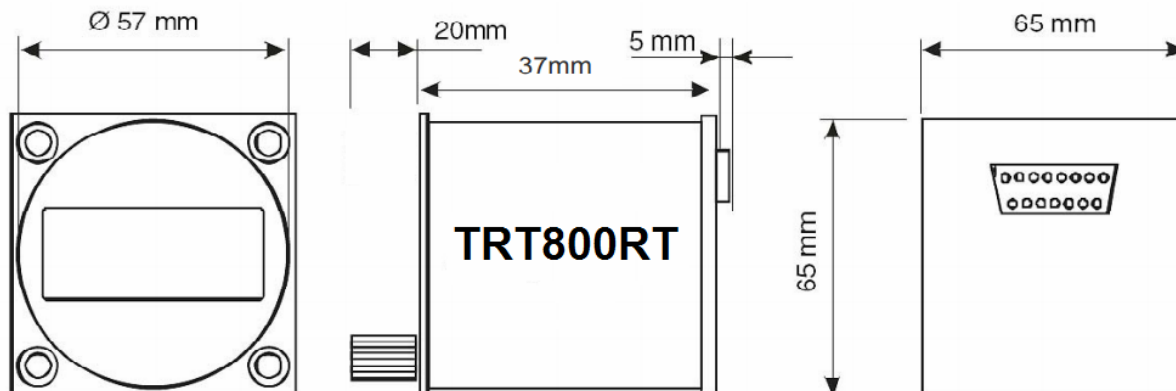

3.8.2 Mounting Advices

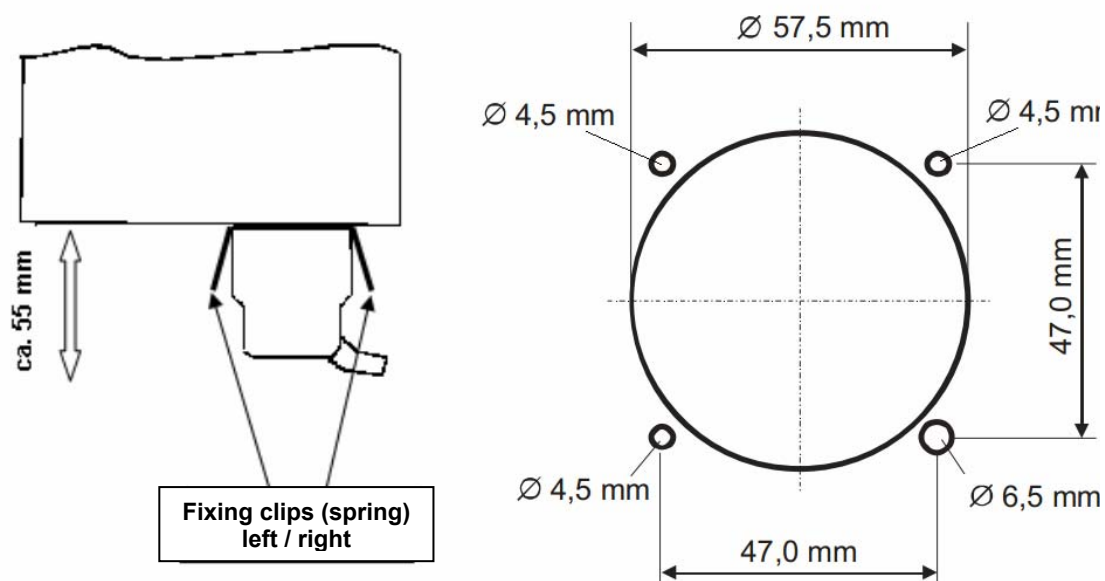

	<p>Connector (plug) has to be clamped with both spring locks. New screws may be turned in more than max. 15mm into the device – even if no hard limit is noticeable.</p>
--	--

4 APPENDIX

4.1 Technical Data

Compliance	CS-ETSO-2C112a EASA.210.269
Applicable Documents	CS-ETSO-2C112a EUROCAE ED-73B Class 1 Level 2es EUROCAE ED-26 RTCA DO-160D RTCA DO-178B Software-Level D
Temperature Ranges Operation Storage	-20 °C to +55 °C; for 30 min +70°C -55 °C to +85 °C
Altitude Range	≤ 35 000 ft
Shock	6 G Operation 20 G crash safety
Environmental Categories	RTCA DO-160D Env.Cat.: [C1Z]CAA[SM]XXXXXXZBAAA[TT]M[B3F3] XXA
Power Supply	13,8 VDC (10 VDC .. 16 VDC) 0,06 A @ 13,8 VDC (typ.) 600 mW (max)
Fuse	External 1A-slow-blow fuse
Mounting	Panel cut-out d=57,5 mm
Weight	0,2 kg (0.43 lbs.)

4.2 Environmental Conditions

Characteristic DO-160D	Section	Cat.	Condition
Temperature / Altitude	4.0		
Low ground survival temperature	4.5.1	C1	- 55°C
Low operating temperature	4.5.1		- 20°C
High ground survival Temperature	4.5.2		+ 85°C
High Short-time Operating Temperature	4.5.2		+ 70°C
High Operating Temperature	4.5.3		+ 55°C
In-Flight Loss of Cooling	4.5.4	Z	No auxiliary cooling required
Altitude	4.6.1	C1	35 000 ft
Temperature Variation	5.0	C	2°C change rate minimum per minute
Humidity	6.0	A	
Shock	7.0	A	6 G operational shocks 20 G Crash Safety Test Type R in all 6 directions
Vibration	8.0	S	Vibration Curve M
Explosion Proofness	9.0	X	No test required
Water Proofness	10.0	X	No test required
Fluids Susceptibilities	11.0	X	No test required
Sand and Dust	12.0	X	No test required
Fungus Resistance	13.0	X	No test required
Salt Spray	14.0	X	No test required
Magnetic Effect	15.0	Z	Less than 0,3 m
Power Input (DC)	16.0	B	
Voltage Spike Conducted	17.0	A	
Audio Frequency Conducted Susceptibility	18.0	A	

Characteristic DO-160D	Section	Cat.	Condition
Induced Signal Susceptibility	19.0	A	
Radio Frequency Susceptibility	20.0	TT	
Emission of RF Energy	21.0	M	
Lightning Induced Transient Susceptibility	22.0	B3F3	
Lightning Direct Effects	23.0	X	No test required
Icing	24.0	X	No test required
Electrostatic Discharge (ESD)	25.0	A	

Notes:

Funkwerk Avionics GmbH

Heinz-Strachowitz-Str. 4
DE-86807 Buchloe
Germany

phone.: +49-8241 80066 0

fax.: +49-8241 80066 99

E-mail:

service@funkwerk-avionics.com

www.funkwerk-avionics.com